

High-Pressure Needle Valves

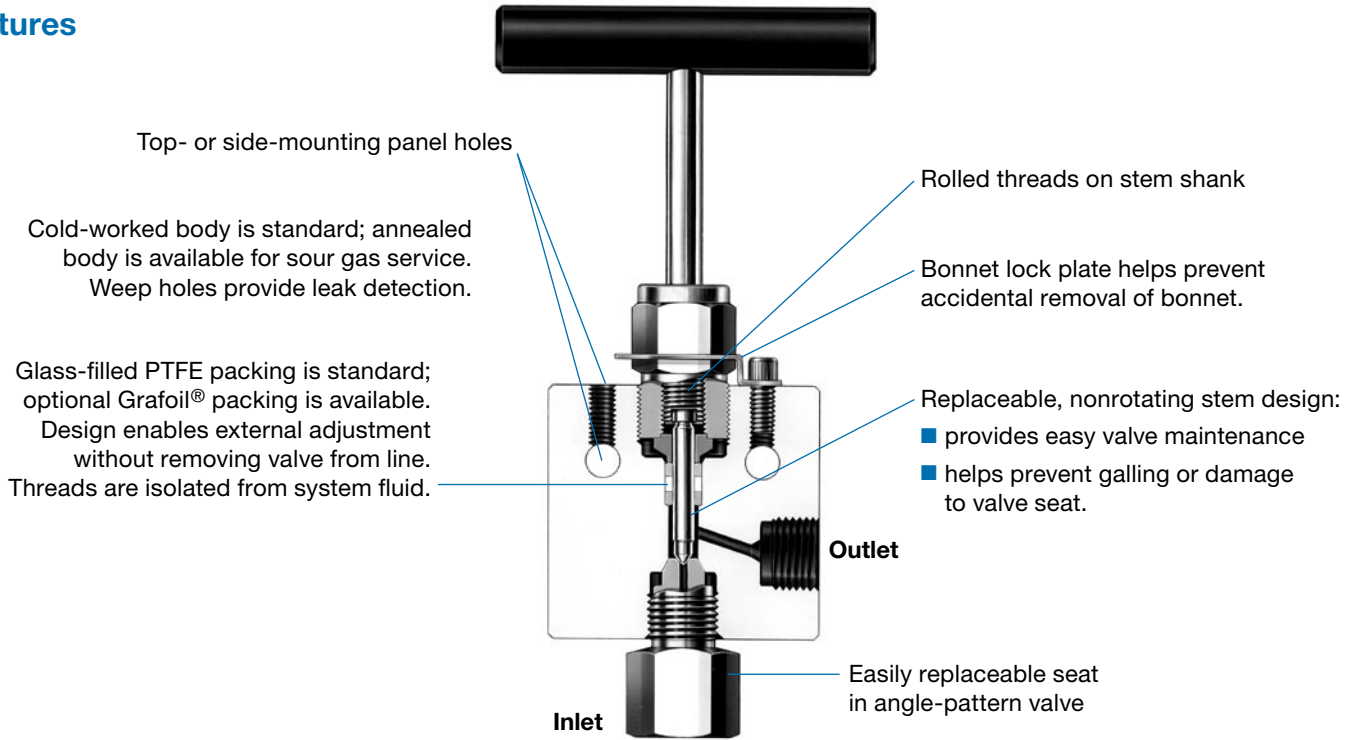

- Working pressures up to 45 000 psig (3100 bar)
- Temperatures up to 450°F (232°C)
- Weep holes for leak detection
- Packing below stem threads
- Nonrotating stem design
- Straight thread high-pressure female or female NPT end connections

Features



Pressure-Temperature Ratings

- 410 series ratings are based on Grafoil packing. Ratings are limited to 450°F (232°C) with glass-filled PTFE packing.
- 445, 645, and 945 series ratings are based on glass-filled PTFE packing. Ratings with Grafoil packing are equal to 410 series ratings.

Series	410	445, 645, 945
Temperature, °F (°C)	Working Pressure, psig (bar)	
-65 (-53) to 100 (37)	10 000 (689)	45 000 (3102)
200 (93)	9 290 (640)	41 800 (2882)
300 (148)	8 390 (578)	37 700 (2599)
400 (204)	7 705 (530)	34 600 (2385)
450 (232)	7 435 (512)	33 400 (2302)
500 (260)	7 165 (493)	—
550 (287)	6 970 (480)	—
600 (315)	6 770 (466)	—
650 (343)	6 660 (458)	—
700 (371)	6 480 (446)	—
750 (398)	6 335 (436)	—
800 (426)	6 230 (429)	—
850 (454)	6 085 (419)	—

Flow Coefficient at Turns Open

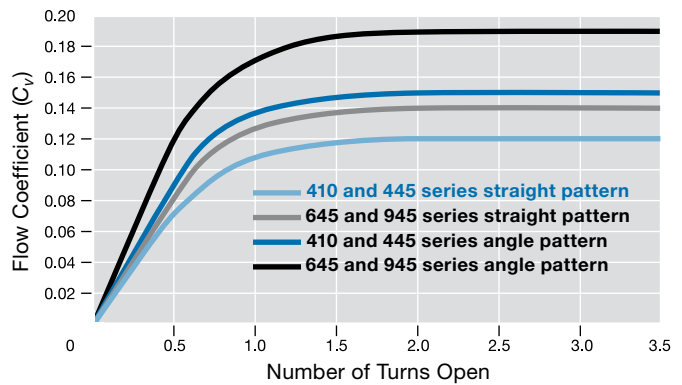

Operating Torque

Torque required for shutoff at maximum pressure rating is 50 in.-lb (5.7 N·m) . Overtightening of valve will result in reduced seat life.

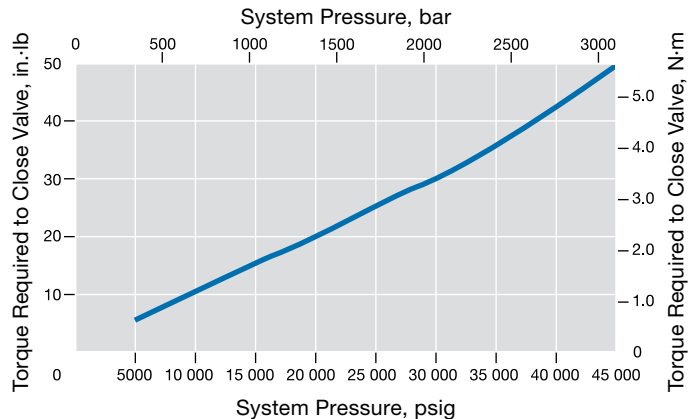

Testing

Every Swagelok® high-pressure needle valve is factory tested with water up to its maximum pressure rating to a requirement of no detectable leakage at the seat and packing. Leak testing with gas is available; see page 4.

Materials of Construction

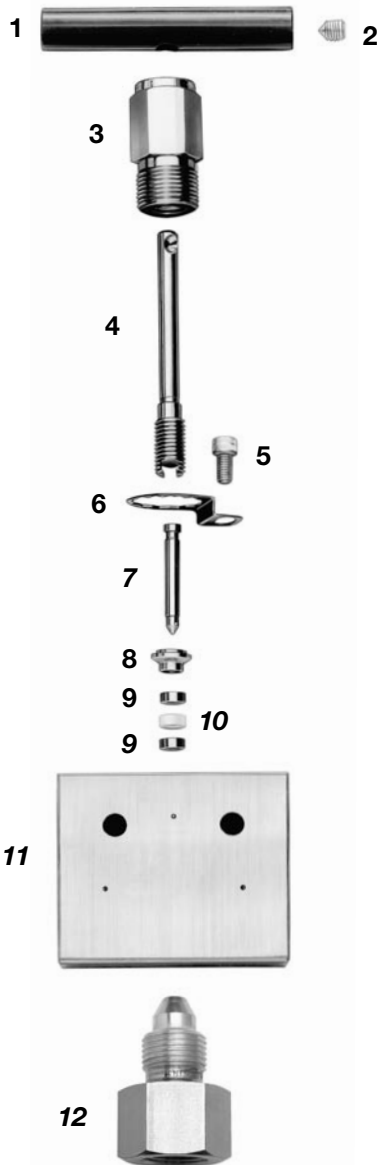

Component	Material Grade/ ASTM Specification
1 Handle (410) (445, 645, 945)	Red anodized aluminum 2024-T4/B211 Black anodized aluminum 2024-T4/B211
2 Handle screw	Cadmium-plated carbon steel
3 Bonnet nut	Phosphor bronze 544/B139
4 Stem shank	455 SS/A564
5 Lock screw	316 SS
6 Lock plate	316 SS/A240
7 Stem	440C SS/A276
8 Spacer	316 SS/A276
9 Gland	316 SS/A276
10 Packing	Glass-filled PTFE
11 Body	316 SS/A479
12 Replaceable seat (angle pattern)	316 SS/A479 with silver-plated threads
Lubricant	Copper/molybdenum disulfide

Wetted components listed in *italics*.

Ordering Information and Dimensions

Dimensions, in inches (millimeters), are for reference only and are subject to change.

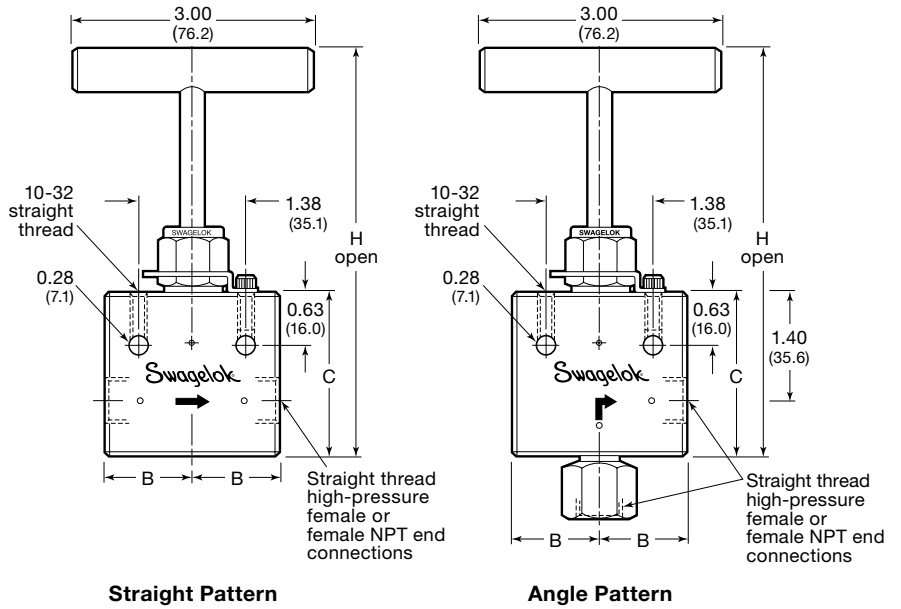

Valve Size in.	Port Thread Size	Ordering Number	Series	C _v	Dimensions, in. (mm)			
					Orifice	B	C	H
Straight Pattern								
1/4	1/4 in. female NPT	SS-410-FP	410	0.12	0.093 (2.4)	1.07 (27.2)	2.02 (51.3)	4.91 (125)
	9/16-18	SS-445-FP	445					
3/8	3/4-16	SS-645-FP	645	0.14		1.39 (35.3)	2.27 (57.7)	5.16 (131)
9/16	1 1/8-12	SS-945-FP	945			1.39 (35.3)	2.58 (65.5)	5.47 (139)
Angle Pattern								
1/4	1/4 in. female NPT	SS-410-FPAR	410	0.15	0.093 (2.4)	1.39 (35.3)	2.27 (57.7)	5.47 (139)
	9/16-18	SS-445-FPAR	445				2.02 (51.3)	4.91 (125)
3/8	3/4-16	SS-645-FPAR	645	0.19		2.27 (57.7)	5.16 (131)	
9/16	1 1/8-12	SS-945-FPAR	945			2.58 (65.5)	5.47 (139)	

Options and Accessories

Stem Options

Valves are standard with 440C stainless steel stems. To order valves with optional stems, add a stem material designator to the valve ordering number.

Stem Material	Designator
440C SS with cobalt-based alloy tip	-STE
S17400 SS	-174

Example: SS-410-FP-**STE**

High-Temperature Stem Packing

Grafoil stem packing is available for temperatures up to 850°F (454°C). To order valves with factory-assembled Grafoil packing, add **-G** to the valve ordering number.

Example: SS-410-FP-**G**

Stem Packing Kits

PTFE and Grafoil stem packing kits are available for all series. Kits contain glands, packing, lubricants, and instructions.

Stem Packing	Kit Ordering Number
PTFE	T-91K-445
Grafoil	G-91K-445

Replaceable Seats

Angle-pattern valves have a one-piece replaceable seat with an integral female NPT or female straight thread high-pressure end connection. Seats are manufactured from 316 stainless steel and have silver-plated threads. To order a replaceable seat, select an ordering number.

Valve	Replaceable Seat Ordering Number
SS-410-FPAR	SS-410-RS-4F
SS-445-FPAR	SS-445-RS-44F
SS-645-FPAR	SS-645-RS-64F
SS-945-FPAR	SS-945-RS-94F

For proper assembly of a replaceable seat, tighten one-eighth turn past finger-tight with a wrench.

Optional Gas Seat Test

Leak testing with nitrogen at 5000 psig (344 bar) is available. Seats have a maximum allowable leak rate of 0.5 std cm³/min. To order, add **-PU** to the valve ordering number.

Example: SS-410-FP-**PU**

Stainless Steel Bar Handles

To order valves with factory-assembled 316 stainless steel bar handles, add **-SH** to the valve ordering number.

Example: SS-410-FP-**SH**

Spare Handles

To order handles as spare parts, select an ordering number.

Valve Series	Handle Ordering Numbers	
	Aluminum Bar	316 SS Bar
410	A-5K-410-RD	SS-51S-26B
445 645 945	A-5K-445-BK	

Sour Gas Valves

Valves for sour gas service are available. Materials are selected in accordance with NACE MR0175/ISO 15156. The valves have annealed bodies and S17400 stems. The 410 series valve maintains its 10 000 psig (689 bar) rating. The 445, 645, and 945 series valves are rated to 18 000 psig at 100°F (1240 bar at 37°C) with high-pressure ports. To order, add **-SG** to the valve ordering number.

Example: SS-410-FP-**SG**

For more information on valves for sour gas service, contact your authorized Swagelok sales and service representative.

Pneumatically Actuated Valves

Pneumatically actuated valves are designed for remote actuation where manual actuation is difficult or impractical. Pneumatic actuators are available in normally open, normally closed, and double acting modes.

Pressure-Temperature Ratings

To prolong valve life, actuators should be operated at minimum required pneumatic actuator pressures. Ratings for high-pressure valve actuators are:

- 200 psig at 100°F (13.7 bar at 37°C)
- 150 psig at 300°F (10.3 bar at 148°C)

Actuator Pressure at System Pressure

Normally open actuators require a minimum system pressure of 2500 psig (172 bar).

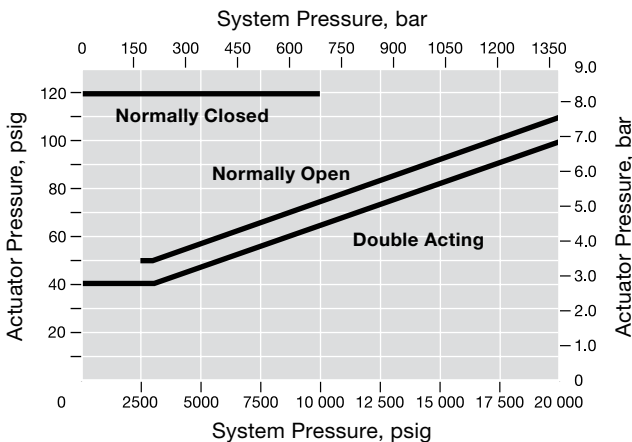

The pressure values shown above are based on the following valve criteria:

- **Valve contains glass-filled PTFE packing.** Other packing materials may substantially alter the force required to actuate the stem.
- **Proper bonnet nut adjustment.** If the bonnet nut is overtightened, the actuating pressure cannot overcome the frictional force between the packing and the stem. Sufficient bonnet nut torque should be maintained to prevent packing leakage while allowing proper actuation.
- **Liquid systems.** While high-pressure gas service generally requires the packing to be tightened, overtightening will prevent proper operation of the actuator.
- **Proper stem nut adjustment.** Stem position affects the spring force on the normally closed and normally open models.

Detailed service and adjustment instructions are included with each pneumatically actuated valve.

⚠ Caution: Actuated assemblies must be properly supported. Inadequate or improper support of the actuated assembly may result in leakage or premature valve failure.

Materials of Construction

Component	Double Acting (-D) and Normally Open (-O)	Normally Closed (-C)
Cylinder, cover, piston, mounting plate, tie rods, tie rod nuts	Black-anodized aluminum	
Piston rod, stem adjustment nut, stem lock nut	416 SS	
Piston rod nut, bonnet nut	316 SS	
Cover screws	Cadmium-plated steel	302 SS
O-rings	Fluorocarbon FKM	
Springs (-O, -C)	302 SS	
Piston rod bushing	—	Bronze

Ordering Information and Dimensions

Dimensions, in inches (millimeters), are for reference only and are subject to change.

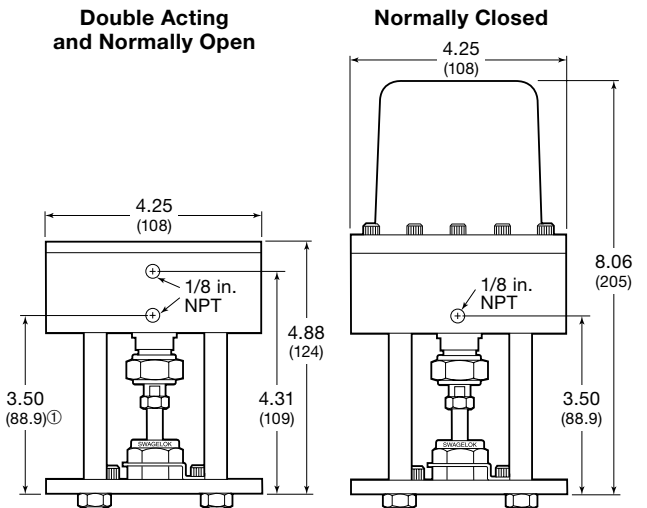

① Double-acting actuator only.

To order valves with a factory-assembled pneumatic actuator, add the actuator mode designator to a valve ordering number.

Actuation Mode	Designator
Normally closed	-C
Double acting	-D
Normally open	-O

Example: SS-410-FP-C

High-Pressure Fittings

See the Swagelok *High-Pressure Fittings* catalog, MS-01-34, for more information.



Tube Fittings

See the Swagelok *Gaugeable Tube Fittings and Adapter Fittings* catalog, MS-01-140, for more information.



Safe Product Selection

When selecting a product, the total system design must be considered to ensure safe, trouble-free performance. Function, material compatibility, adequate ratings, proper installation, operation, and maintenance are the responsibilities of the system designer and user.

Caution: Do not mix or interchange parts with those of other manufacturers.

Warranty Information

Swagelok products are backed by The Swagelok Limited Lifetime Warranty. For a copy, visit swagelok.com or contact your authorized Swagelok representative.

Swagelok—TM Swagelok Company
Grafoil—TM UCAR Carbon Company, Inc.
© 2002, 2008 Swagelok Company
Printed in U.S.A., GLI
October 2008, R1
MS-02-160