

# MINI DIAPHRAGM VACUUM PUMPS ROUGHING PUMPS

DATA SHEET E 006

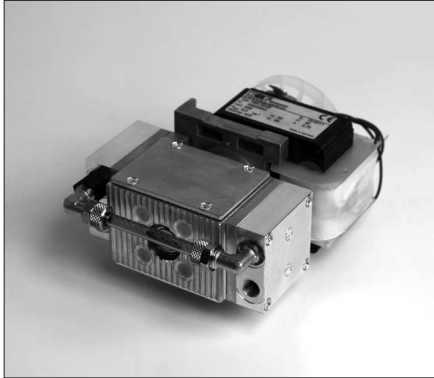

**N 84.3 ANE**

### Concept

The mini diaphragm vacuum pumps from KNF are based on a simple principal - an elastic diaphragm, fixed on its edge, moves up and down its central point by means of an eccentric. In this way the medium is transferred using automatic valves.

The pumps are equipped with the patented stress-optimized structured diaphragm, resulting in a high pneumatic performance, a durable product and compact size.

Thanks to the KNF modular system, the parts used to transfer the gases can be made from materials with varying degrees of durability. The pumps can be driven by either AC or DC motors.



**N 84.4 ANDC**

### Features

**Uncontaminated flow**

No contamination of the media due to oil-free operation

**Maintenance-free**

**Compact size**

due to structured diaphragm

**High performance**

because of structured diaphragm

**High level of gas tightness**

**Long product life**

thanks to structured diaphragm

**Very quiet and little vibration**

**Ready for assembly**

**Can operate in any installed position**

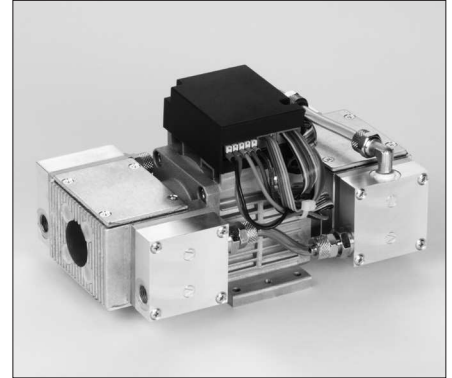

**N 84.4 ANDC-B**

### Areas of use

The mini diaphragm pumps offer a high level of performance despite their small size, as well as an excellent price performance ratio. They are required especially in the fields of analysis, medicine, production technology or be used as roughing pump for turbomolecular pumps.

The pumps are used for sucking gases, taking samples (even liquids in a vacuum) and evacuating vessels and systems.

The AC models are suited for use in machinery which is permanent or mains-operated. Mini diaphragm pumps for portable and stand-alone equipment require DC power supplies.

Performance data					
Type	Delivery (l/min)	Vacuum (mbar absolute)	atm. Pressure	Pressure (bar g)	Weight (kg)
N 84.3 ANE	4.2	7		0.3	1.4
N 84.3 ANDC	5	7		0.3	0.9
N 84.4 ANDC	4.8	2		0.3	1.6
N 84.4 ANDC-B	4.8	2		0.3	1.8
N 84.4 AN.29DC-B	4.8	2		0.3	1.8



# N 84.4 ANDC

## Performance data

Type	Delivery at atm. pressure (l/min) <sup>1)</sup>	Max. operating pressure (bar g)	Ultimate vacuum (mbar abs.)
N 84.4 ANDC	4.8	0.3	2

<sup>1)</sup> Liter at STP

## Motor data

Voltage	12 V	24 V
I <sub>max</sub> (A)	1.3	0.85

## Pump material

Type	Pump head	Diaphragm	Valves
N 84.4 ANDC	Aluminum	PTFE-coated	EPDM

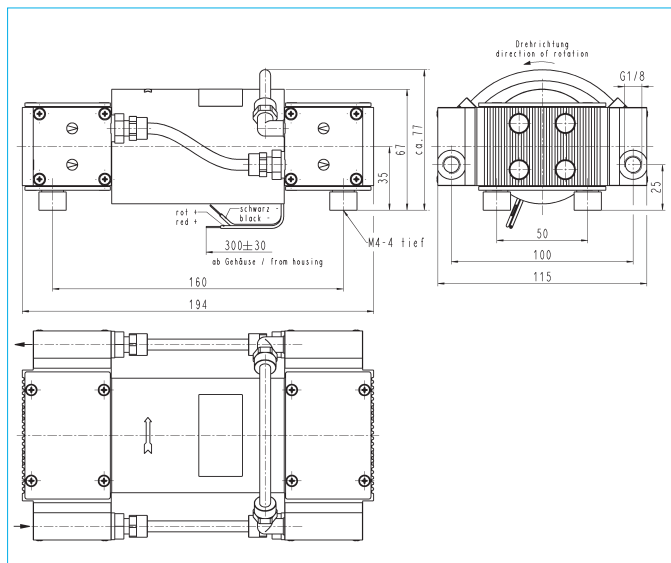

# N 84.4 ANDC-B | AN.29DC-B

## Performance data

Type	Delivery at atm. pressure (l/min) <sup>1)</sup>	Max. operating pressure (bar g)	Ultimate vacuum (mbar abs.)
N 84.4 ANDC-B	4.8	0.3	2
N 84.4 AN.29DC-B	1.0-4.8	0.3	up to 2

## Motor data

Voltage	24 V
I <sub>max</sub> (A)	1.2

## Pump material

Type	Pump head	Diaphragm	Valves
N 84.4 ANDC-B	Aluminum	PTFE-coated	EPDM
N 84.4 AN.29DC-B	Aluminum	PTFE-coated	EPDM

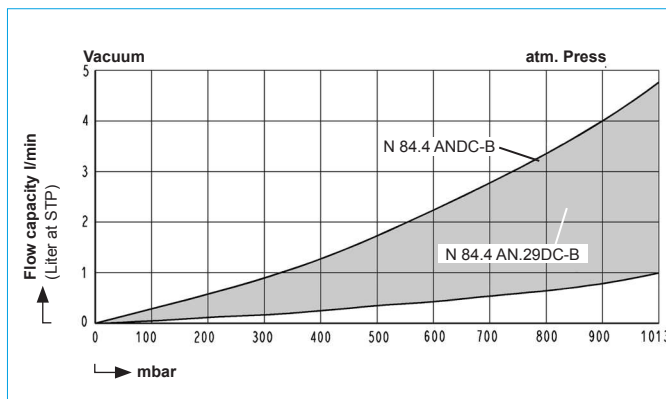
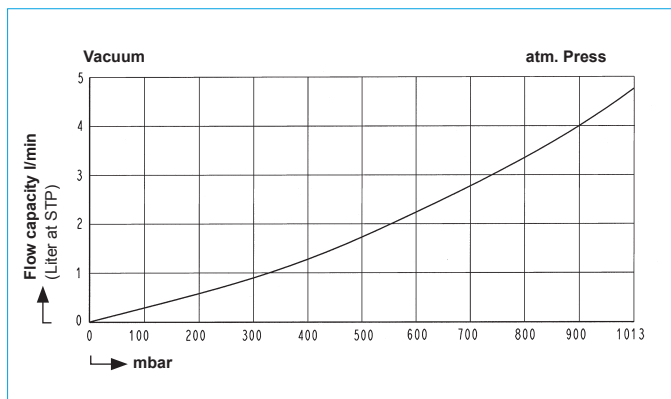
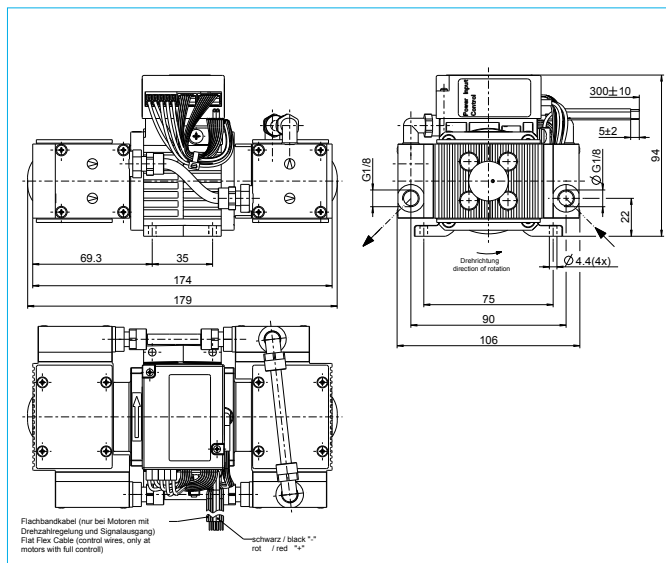

## Pump down time for 1 l receiver

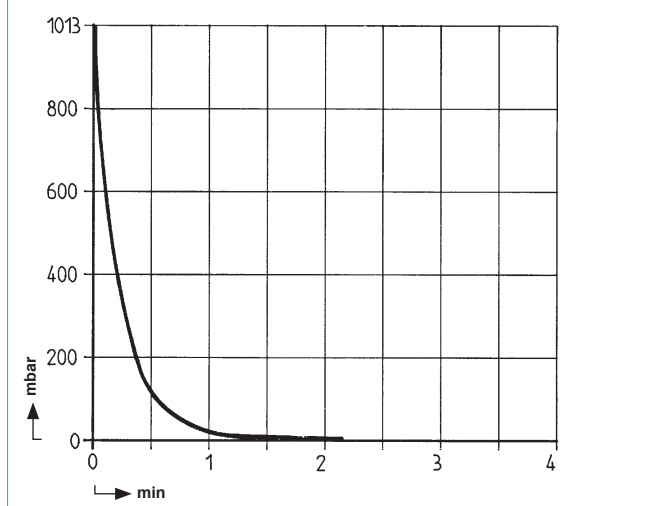

## Pump down time for 1 l receiver

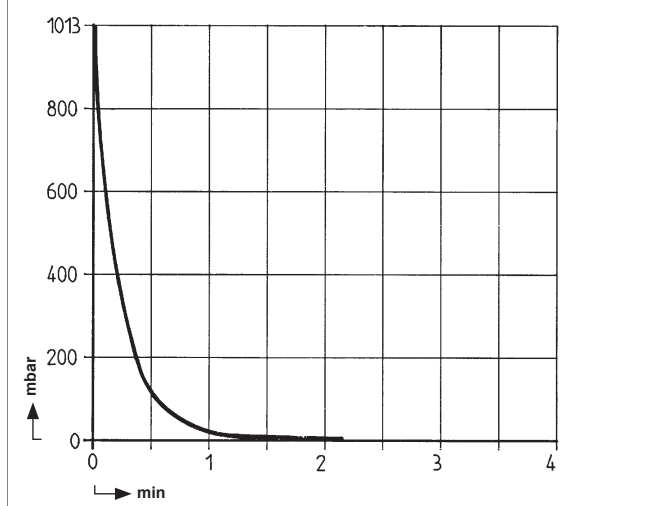

## HINTS ON FUNCTION, INSTALLATION AND TECHNIQUE

### Function of KNF diaphragm vacuum pumps and compressors

An elastic diaphragm is moved up and down by an eccentric (see illustration). On the down-stroke it draws the air or gas being handled through the inlet valve. On the up-stroke the diaphragm forces the medium through the exhaust valve and out of the head. The compression chamber is hermetically separated from the drive mechanism by the diaphragm. The pumps transfer, evacuate and compress completely oil-free.

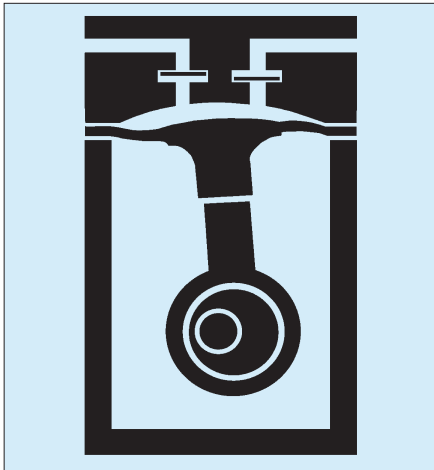

### Hints on installation and operation

- Range of use: Transferring air and gases at temperatures between +5 °C and +40 °C
- Permissible ambient temperature: between +5 °C and +40 °C
- These pumps are not suitable for aggressive gases and vapors. In these cases there are other products in the KNF program - please ask us for details.
- The standard pumps are not suitable for use in areas where there is a risk of explosion. In these cases there are other products in the KNF program - please ask us for details.
- To prevent the maximum operating pressure being exceeded, restriction or regulation of the air flow should only be carried out in the suction line.
- Components connected to the pump must be designed to withstand the pneumatic performance of the pump.
- Install the pump so that the fan can draw in sufficient cooling air.
- Fit the pump at the highest point in the

system, so that condensate cannot collect in the head of the pump - that prolongs working-life.

### Technical details

Motors with other voltages, frequencies and protection classes on request.

Description	Accessories	
	Order No.	Details
Silencer/Filter	000345	G 1/8
Hose connector	001936	G 1/8 / PA
Rubber foot	024435	2x (for N 84.3 ANE)

### KNF Neuberger GmbH Pumps + Systems

Alter Weg 3  
D-79112 Freiburg, Germany  
Tel. +49 7664 5909 0  
Fax +49 7664 5909 99  
info@knf.de  
www.knf.de

## SALES CENTERS

### Germany

KNF Neuberger GmbH  
D-79112 Freiburg  
Tel. +49 7664 5909 0  
info@knf.de  
www.knf.de

### Benelux Netherlands

KNF Verder B.V.  
NL-3451 GG Vleuten  
Tel. +31 30 677 92 40  
info@knf-verder.nl  
www.knf-verder.nl

### Benelux Belgium and Luxemburg

KNF Verder N.V.  
B-2630 Aartselaar  
Tel. +32 3 871 96 24  
info@knf.be  
www.knf.be

### China

KNF Technology (Shanghai) Co., Ltd.  
Shanghai 201203  
Tel. +86 21 5109 9695  
info@knf.com.cn  
www.knf.com.cn

### France, Morocco, Tunisia, Algeria

KNF Neuberger SAS  
F-68128 Village-Neuf  
Tel. +33 389 70 35 00  
info@knf.fr  
www.knf.fr

### UK

KNF Neuberger U.K., Ltd.  
Witney, Oxfordshire OX28 4FA  
Tel. +44 1993 77 83 73  
info@knf.co.uk  
www.knf.co.uk

### India

KNF Pumps + Systems (India) Pvt. Ltd.  
Hinjewadi, Pune 411 057  
Tel. +91 20 640 13 923  
+91 20 640 08 923  
info@knfpumps.in  
www.knfpumps.in

### Italy

KNF ITALIA S.r.l.  
I-20063 Cernusco s. Naviglio MI  
Tel. +39 02 272 03 860  
info@knf.it  
www.knf.it

### Japan

KNF Japan Co.Ltd.  
Tokyo 104-0033  
Tel. +81 3 3551 7931  
info@knf.co.jp  
www.knf.co.jp

### Korea

KNF Neuberger Ltd.  
135-502, Seoul  
Tel. +82 2 959 0255  
knf@knfkorea.com  
www.knfkorea.com

### Sweden, Finland, Denmark, Norway

KNF Neuberger AB  
SE-11743 Stockholm  
Tel. +46 8 744 51 13  
info@knf.se  
www.knf.se

### Switzerland

KNF Neuberger AG  
CH-8362 Balterswil  
Tel. +41 71 973 99 30  
knf@knf.ch  
www.knf.ch

### Taiwan

KNF Neuberger Ltd.  
Taipei City, 11490  
Tel. +886 2 2794 1011  
knftwn@knftwn.com.tw  
www.knftwn.com.tw

### USA, Canada

KNF Neuberger, Inc.  
Trenton, New Jersey 08691-1810  
Tel. +1 609 890 8600  
knfusa@knf.com  
www.knfusa.com

### Latin America

Tel. +1 609 649 1010  
gb@knf.com  
www.knf.com/es